



Surface Mount



Ceiling Mount

Surface and ceiling mountable without additional accessories

The Hybrid PL Exit Sign combines Ecoglo's internationally recognised photoluminescent technology with Class II LEDs and the next generation patented electronics.

Requiring no battery backup, the internally illuminated photoluminescent exit sign is effective in all lighting scenarios. Designed to be used in and about buildings to identify escape routes to meet NCC 2019 E4.8.

The signs will be clearly visible and readily understandable under all conditions of foreseeable use, including emergency conditions.

COMPLIANCE

Ecoglo Hybrid PL Exit Signs can be used to meet NCC 2019 E4.8 or can be used in Performance Solutions.

PERFORMANCE

Provides a minimum of 90 minutes of visibility after failure of the main lighting.

INPUT

230/240 Vac, 50/60 Hz, Single and Double Sided Sign

RATED POWER CONSUMPTION

0.5W Single and Double Sided Sign

SUPPLY

The signs are currently available in one size.

See table for maximum viewing distance of each sign.

PRODUCT CODE	PRODUCT DESCRIPTION	GRAPHICS INCLUDED	MAXIMUM VIEWING DISTANCE
HYU1.2	Single Sided Hybrid Sign	1 x RM, 1 x RMR, 1 x RML	16 metres
HYU1.2-RMRL	Single Sided Hybrid Sign	1 x RM Double Arrow	16 metres
HYU1.2-RMB	Single Sided Hybrid Sign	1 x RM Low Light Black	16 metres
HYU1.2-EXB	Single Sided Hybrid Sign	1 x Exit Low Light Black	24 metres
HYU1.2-EX	Single Sided Hybrid Sign	1 x Exit	24 metres
HYU1.2-EXR	Single Sided Hybrid Sign	1 x Exit Right	16 metres
HYU1.2-EXL	Single Sided Hybrid Sign	1 x Exit Left	16 metres
HYU2.2	Double Sided Hybrid Sign	2 x RM, 1 x RMR, 1 x RML	16 metres
HYU2.2-RMRL	Double Sided Hybrid Sign	2 x RM Double Arrow	16 metres
HYU2.2-EX	Double Sided Hybrid Sign	2 x Exit	24 metres
HYU2.2-EXRL	Double Sided Hybrid Sign	1 x Exit Right, 1 x Exit Left	16 metres
HYU2.2-EXB	Double Sided Hybrid Sign	2 x Exit Low Light Black	24 metres

Above signs include one or more of graphics shown below.



RM
Exit straight on from here



RML
Exit left from here



RMR
Exit right from here



RM DOUBLE ARROW
Exit right or left from here



RM (Low Light)
Exit straight on from here



EXIT (Low Light)
Exit straight on from here



EXIT
Exit straight on from here



EXIT LEFT
Exit left from here



EXIT RIGHT
Exit right from here

PRODUCT FEATURES

- LED/Photoluminescent Exit Sign System
- Meets NCC 2019 E4.8
- No batteries or backup power required for power outages
- High efficiency low power consumption LED charging source
- Long life LEDs (>100,000 hours)
- Works in all lighting scenarios
- Non-toxic, non-radioactive photoluminescent technology

INTERNAL SPECIFICATIONS

AC LED: standard 230/240 VAC input

PRODUCT DIMENSIONS

Height: 221mm

Width: 362mm

Depth: 62mm

PRODUCT WEIGHT

Single Sided Sign: 1.30kg

Double Sided Sign: 1.45kg

INSTALLATION

The sign can be fixed directly to the ceiling or wall using the moulded mounting holes on each end of the sign. Flag and recess mount installation kits are coming soon.

COMPREHENSIVE WARRANTY

10 years.

PROTECTION RATING

IP44 - Splashproof

(Suitable for outdoor environments where there is overhead protection such as a building eave or canopy, but should not be installed in fully exposed outdoor locations.)

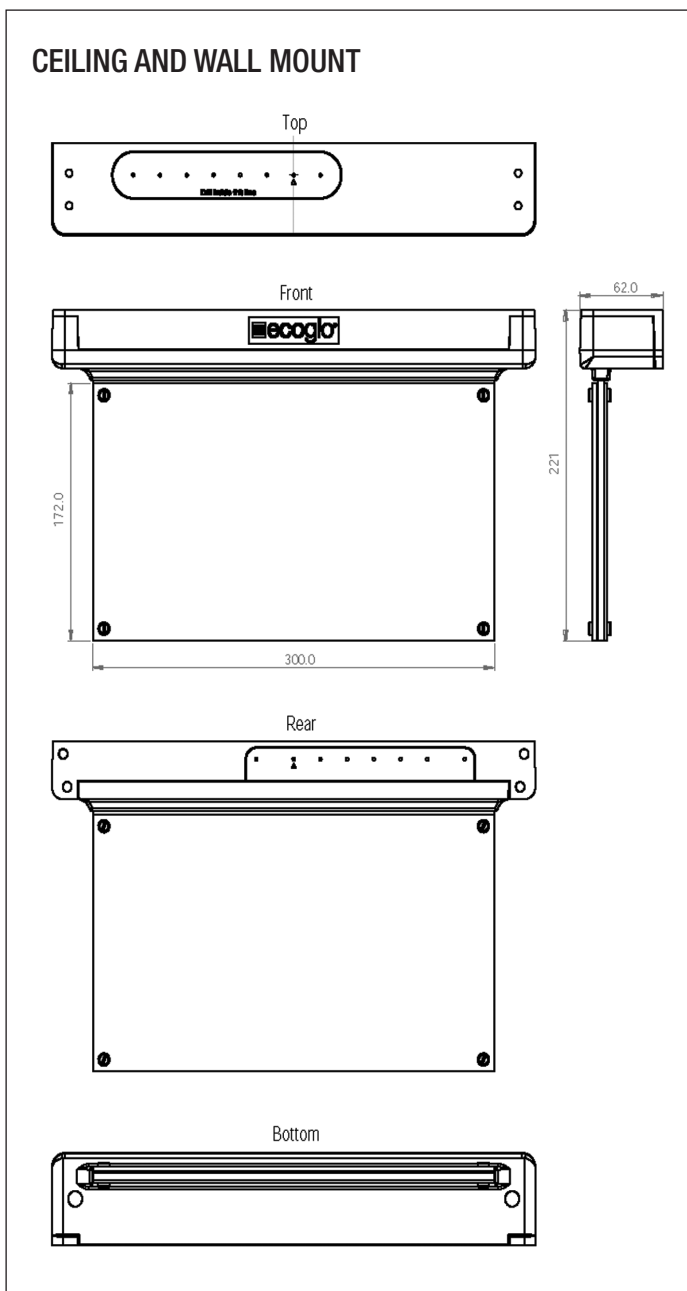

Contact

Ecoglo Australia

Ground floor, 470 St. Kilda Road, Melbourne VIC 3004

Office: +61 3 8691 5288

Mob: +61 400 525 625

Email: Australia@ecoglo.com **Web:** www.ecoglo.com.au